



TEST REPORT

Applicant : Shenzhen KNOX Energy Co., Ltd.
Address : No. 910, Building B, Fucheng Building, Kexing Park, Fuhua Road, Longhua District, Shenzhen, China. 518000

Manufacturer : Shenzhen KNOX Energy Co., Ltd.
Address : No. 910, Building B, Fucheng Building, Kexing Park, Fuhua Road, Longhua District, Shenzhen, China. 518000

Product Name : MPPT SOLAR INVERTER
Trade Mark : 

Model No. : XZ-11.2kW-18000pV, XZ-9.2kW-16000pV
Ratings : See the copy of marking plate on page 3-4
Standard : IEC 61683:1999 -Photovoltaic systems
- Power conditioners - Procedure for measuring efficiency

Date of Receiver : April 11, 2026
Date of Test : April 11, 2026 to April 28, 2026
Date of Issue : April 30, 2026
Test Report Form No : NTCS-IEC61683-A1
Test Result : Pass *

This Test Report is Issued Under the Authority of:

Compiled by

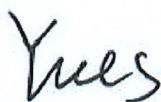

Yves Zhong / Engineer

Approved by



Han Song / Manager

***Remarks:**

The results shown in this test report refer only to the sample(s) tested, this test report cannot be reproduced, except in full, without prior written permission of Shenzhen Nore Testing Center Co., Ltd. The report would be invalid without specific stamp of test institute and the signatures of compiler and approver.

Copy of marking plate:

Rating label

 <p>MODEL: XZ-11.2kW-18000pV</p> <p>PV INPUT</p> <table border="0"> <tr><td>Nominal operating voltage</td><td>360Vdc</td></tr> <tr><td>Vmax PV</td><td>500Vdc</td></tr> <tr><td>PV input voltage range</td><td>120-500Vdc</td></tr> <tr><td>PV input current</td><td>2*27A</td></tr> <tr><td>Isc PV</td><td>2*35A</td></tr> <tr><td>Max. PV Input Power</td><td>18000W</td></tr> </table> <p>AC OUTPUT</p> <table border="0"> <tr><td>Nominal operating voltage</td><td>230Vac</td></tr> <tr><td>Nominal output current</td><td>48.7A</td></tr> <tr><td>Nominal operating frequency</td><td>50/60Hz</td></tr> <tr><td>Maximum power</td><td>11200W</td></tr> <tr><td>Power factor range</td><td>0.9 lead-0.9lag</td></tr> </table> <p>AC INPUT</p> <table border="0"> <tr><td>Nominal operating voltage</td><td>230Vac</td></tr> <tr><td>Nominal input current</td><td>60A</td></tr> <tr><td>Nominal operating frequency</td><td>50/60Hz</td></tr> </table> <p>BATTERY</p> <table border="0"> <tr><td>Battery rated voltage</td><td>48Vdc</td></tr> <tr><td>Maximum battery current</td><td>210A</td></tr> </table> <p>Ambient temperature: -25~+50°C Enclosure: IP54 Safety class: I</p> <div style="display: flex; justify-content: space-around; align-items: center;">      </div> <p>SHENZHEN KNOX ENERGY CO. LTD www.knoxpv.com hello@knoxpv.com DESIGNED IN TAIWAN MADE IN CHINA</p> 	Nominal operating voltage	360Vdc	Vmax PV	500Vdc	PV input voltage range	120-500Vdc	PV input current	2*27A	Isc PV	2*35A	Max. PV Input Power	18000W	Nominal operating voltage	230Vac	Nominal output current	48.7A	Nominal operating frequency	50/60Hz	Maximum power	11200W	Power factor range	0.9 lead-0.9lag	Nominal operating voltage	230Vac	Nominal input current	60A	Nominal operating frequency	50/60Hz	Battery rated voltage	48Vdc	Maximum battery current	210A	 <p>MODEL: XZ-9.2kW-16000pV</p> <p>PV INPUT</p> <table border="0"> <tr><td>Nominal operating voltage</td><td>360Vdc</td></tr> <tr><td>Vmax PV</td><td>500Vdc</td></tr> <tr><td>PV input voltage range</td><td>120-500Vdc</td></tr> <tr><td>PV input current</td><td>2*27A</td></tr> <tr><td>Isc PV</td><td>2*35A</td></tr> <tr><td>Max. PV Input Power</td><td>16000W</td></tr> </table> <p>AC OUTPUT</p> <table border="0"> <tr><td>Nominal operating voltage</td><td>230Vac</td></tr> <tr><td>Nominal output current</td><td>40A</td></tr> <tr><td>Nominal operating frequency</td><td>50/60Hz</td></tr> <tr><td>Maximum power</td><td>9200W</td></tr> <tr><td>Power factor range</td><td>0.9 lead-0.9lag</td></tr> </table> <p>AC INPUT</p> <table border="0"> <tr><td>Nominal operating voltage</td><td>230Vac</td></tr> <tr><td>Nominal input current</td><td>60A</td></tr> <tr><td>Nominal operating frequency</td><td>50/60Hz</td></tr> </table> <p>BATTERY</p> <table border="0"> <tr><td>Battery rated voltage</td><td>48Vdc</td></tr> <tr><td>Maximum battery current</td><td>190A</td></tr> </table> <p>Ambient temperature: -25~+50°C Enclosure: IP54 Safety class: I</p> <div style="display: flex; justify-content: space-around; align-items: center;">      </div> <p>SHENZHEN KNOX ENERGY CO. LTD www.knoxpv.com hello@knoxpv.com DESIGNED IN TAIWAN MADE IN CHINA</p> 	Nominal operating voltage	360Vdc	Vmax PV	500Vdc	PV input voltage range	120-500Vdc	PV input current	2*27A	Isc PV	2*35A	Max. PV Input Power	16000W	Nominal operating voltage	230Vac	Nominal output current	40A	Nominal operating frequency	50/60Hz	Maximum power	9200W	Power factor range	0.9 lead-0.9lag	Nominal operating voltage	230Vac	Nominal input current	60A	Nominal operating frequency	50/60Hz	Battery rated voltage	48Vdc	Maximum battery current	190A
Nominal operating voltage	360Vdc																																																																
Vmax PV	500Vdc																																																																
PV input voltage range	120-500Vdc																																																																
PV input current	2*27A																																																																
Isc PV	2*35A																																																																
Max. PV Input Power	18000W																																																																
Nominal operating voltage	230Vac																																																																
Nominal output current	48.7A																																																																
Nominal operating frequency	50/60Hz																																																																
Maximum power	11200W																																																																
Power factor range	0.9 lead-0.9lag																																																																
Nominal operating voltage	230Vac																																																																
Nominal input current	60A																																																																
Nominal operating frequency	50/60Hz																																																																
Battery rated voltage	48Vdc																																																																
Maximum battery current	210A																																																																
Nominal operating voltage	360Vdc																																																																
Vmax PV	500Vdc																																																																
PV input voltage range	120-500Vdc																																																																
PV input current	2*27A																																																																
Isc PV	2*35A																																																																
Max. PV Input Power	16000W																																																																
Nominal operating voltage	230Vac																																																																
Nominal output current	40A																																																																
Nominal operating frequency	50/60Hz																																																																
Maximum power	9200W																																																																
Power factor range	0.9 lead-0.9lag																																																																
Nominal operating voltage	230Vac																																																																
Nominal input current	60A																																																																
Nominal operating frequency	50/60Hz																																																																
Battery rated voltage	48Vdc																																																																
Maximum battery current	190A																																																																



SN: 96141406100001

Warning label

Please scan the following QR code with your smart phone and download Wifi APP.

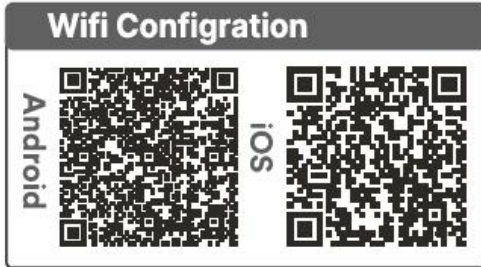

WARNING: FIREHAZARD.
SUITABLE FOR MOUNTING ON CONCRETE OR OTHER NON-COMBUSTIBLE SURFACE ONLY.

CAUTION: THE DC AND AC BREAKER MUST HAVE BEEN TURNED OFF BEFORE SERVICING.

DESIGNED IN TAIWAN | MADE IN CHINA

Remarks:

- For the final production samples, the additional markings which do not give rise to misunderstanding may be added.

General product information:

1. The MPPT SOLAR INVERTER is a non-isolated(transformerless) inverter which works with battery to store energy or convert PV/battery energy to the AC load.
2. The MPPT SOLAR INVERTER shall be used at specified ambient conditions:
 - IP protection class: IP54.
 - Temperature and humidity: -25°C~+50°C, 0% to 100%RH, Condensing.
 - Environment pollution degree: PD2 for inter of unit, PD3 for outside of unit.
 - Altitude: up to 2000m.
3. Double/reinforced insulation provided between primary circuits or hazardous voltage to secondary circuits and DVC A circuits by application of safety isolation transformers, and optocoupler and sufficient clearances and creepage distances within the unit.
4. In order to protect the inverter, user and installer, external circuit breaker shall be equipped for all source ports at the end-use application except for AC input port.
5. When connected to the grid, an isolation transformer must be installed in serial to the AC input.
6. Software versioning: V00; Hardware version number: V00.
7. For MPPT SOLAR INVERTER, all models are the same except for different model number, and ratings.

Topological graph detail see follow figure:

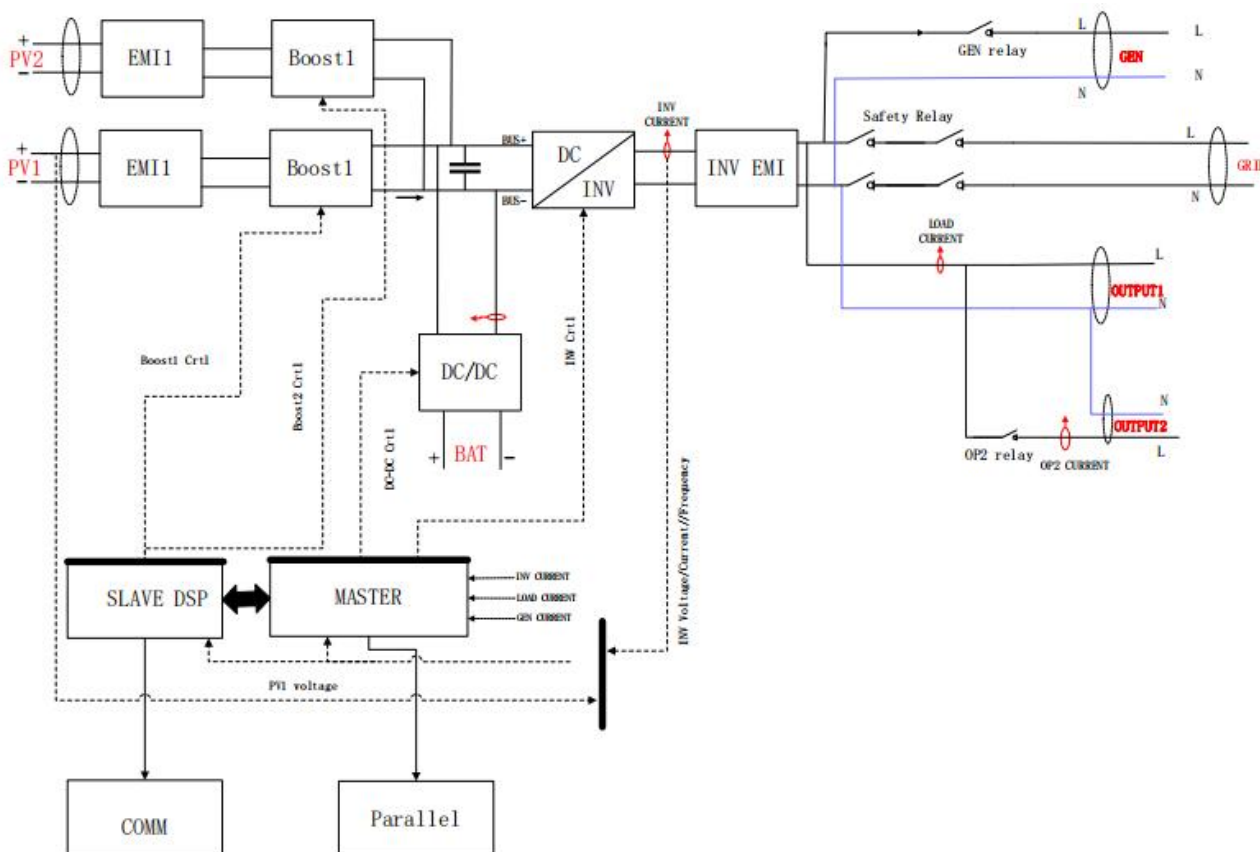

Product Overview:

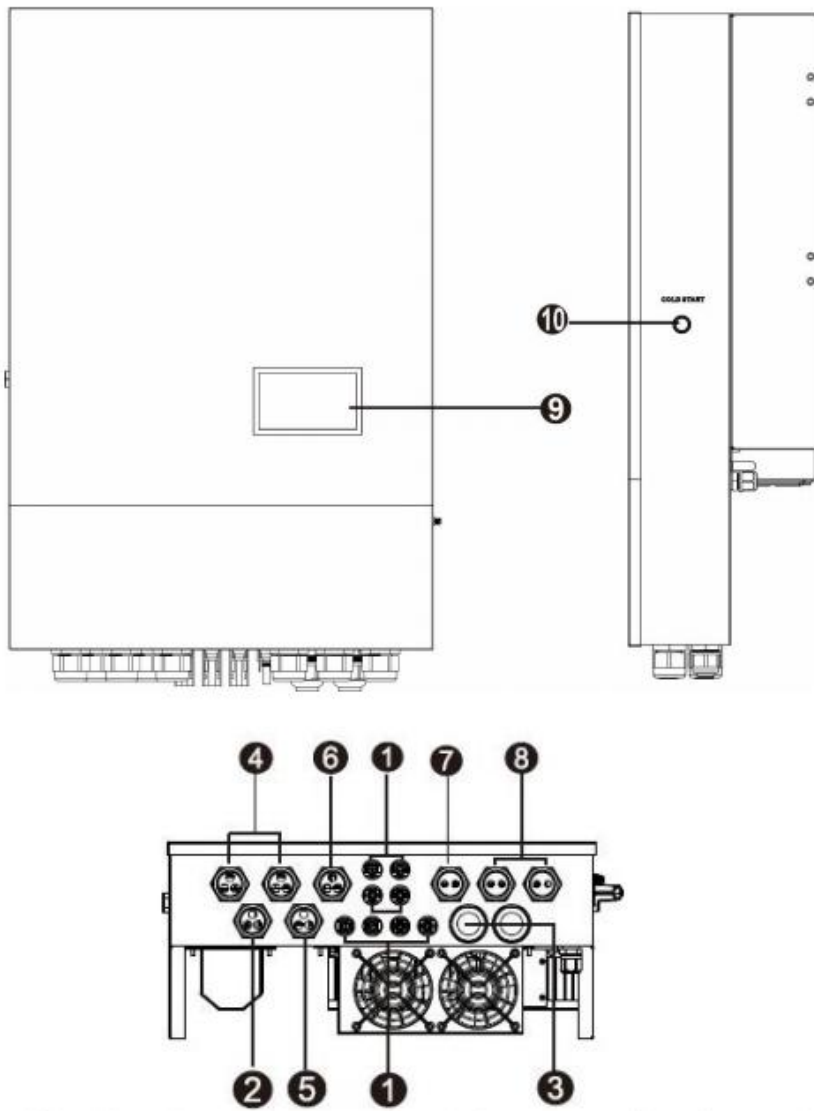

NOTE: For parallel model installation and operation, please check separate parallel installation guide for the details.

- 1. PV connectors
- 2. AC Grid connectors
- 3. Battery connectors
- 4. AC output connectors
- 5. AC Generator connectors
- 6. Sharing current ports & external sensor ports
- 7. Parallel communication ports
- 8. Dry contact/USB/RS-232/BMS communication ports
- 9. LCD display
- 10. Cold start button

Ratings:	
Model	XZ-11.2kW-18000pV
INVERTER Mode	
Input voltage (V)	48Vdc
Input current (A)	210A
Rated output Voltage (V)	230Vac
Max. output Current (A)	48.7A
Rated output Frequency (Hz)	50/60Hz
Rated output Power (W)	11200W
Out Voltage waveform	Pure Sine Wave
PV Mode	
Input voltage (V)	120-500Vdc
Normal voltage (V)	360Vdc
PV MAX INPUT CURRENT(A)	2 * 27A
Rated output Voltage (V)	230Vac
Max. output Current (A)	48.7A
Rated output Frequency (Hz)	50/60Hz
Rated output Power (W)	11200W
Output Voltage waveform	Pure Sine Wave
System	
Weight(kg)	29kg
Size (mm) (D×W×H)	192 x 418 x 633
Model	XZ-9.2kW-16000pV
INVERTER Mode	
Input voltage (V)	48Vdc
Input current (A)	190A
Rated output Voltage (V)	230Vac
Max. output Current (A)	40A
Rated output Frequency (Hz)	50/60Hz
Rated output Power (W)	9200W
Out Voltage waveform	Pure Sine Wave
PV Mode	
Input voltage (V)	120-500Vdc

Normal voltage (V)	360Vdc
PV MAX INPUT CURRENT(A)	2*27A
Rated output Voltage (V)	230Vac
Max. output Current (A)	40A
Rated output Frequency (Hz)	50/60Hz
Rated output Power (W)	9200W
Output Voltage waveform	Pure Sine Wave
System	
Weight(kg)	28kg
Size (mm) (D x W x H)	192 x 418 x 633

Factory : VOLTRONIC POWER TECHNOLOGY (SHENZHEN) CORP.
 Address : 1-5F, Building 5 & 1F Building 7 & 1F Building 9, RunDongSheng Industrial Park, No.467, Section Xixiang, National Highway 107, LongTeng Community, Xixiang, Bao An District, Shenzhen, China

Possible test case verdicts:

- test case does not apply to the test object	N/A
- test object does meet the requirement	Pass (P)
- test object was not evaluated for the requirement....	N/E
- test object does not meet the requirement	Fail (F)

IEC 61683			
Clause	Requirement + Test	Result - Remark	Verdict
4	EFFICIENCY MEASUREMENT CONDITIONS		P
	Efficiency is measured under the conditions in the following clauses.	Refer to Table 1.	P
	Specific conditions may be excluded by mutual agreement when those conditions are outside the manufacturer's allowable operating range.		P
4.1	dc power source for testing		P
	For power conditioners operating with fixed input voltage, the d.c. power source is a storage battery or constant voltage power source to maintain the input voltage	Constant voltage power source used to maintain the input voltage.	P
	For power conditioners that employ maximum power point tracking (MPPT) and shunt-type power conditioners, either a photovoltaic array or a photovoltaic array simulator is utilized.		P
4.2	Temperature		P
	All measurements are to be made at an ambient temperature of 25 °C ± 2 °C.	(25.0-26.2)°C	P
	Other ambient temperatures may be allowed by mutual agreement. However, the temperature used must be clearly stated in all documentation.		N/A
4.3	Output voltage and frequency		P
	The output voltage and frequency are maintained at the manufacturer's stated nominal values.	230Vac, 50/60Hz	P
4.4	Input voltage		P
	Measurements performed in each of the following tests are repeated at three power conditioner input voltages:		P
	a) manufacturer's minimum rated input voltage;	120Vdc	P
	b) the inverter's nominal voltage or the average of its rated input range;	360Vdc	P
	c) 90 % of the inverter's maximum input voltage.	450Vdc	P
	In the case where a power conditioner is to be connected with a battery at its input terminals, only the nominal or rated input voltage may be applied.	48Vdc	P
4.5	Ripple and distortion		P
	Record input voltage and current ripple for each measurement. Also record output voltage and current distortion (if a.c.) or ripple (if d.c.). Ensure that these measurements remain within the manufacturer's specified values.		P
4.6	Resistive loads/utility grid		P
	At unity power factor, or at the intrinsic power factor of grid-connected inverters without power factor adjustment, measure the efficiency for	Refer to Table.	P

IEC 61683			
Clause	Requirement + Test	Result - Remark	Verdict
	power levels of 10 %, 25 %, 50 %, 75 %, 100 % and 120 % of the inverter's rating. Stand-alone inverters are also measured at a power level of 5 % of rated. The power conditioner test is conducted with a specified resistive and reactive grid impedance.		
4.7	Reactive loads		N/A
	For stand-alone inverters, measure the efficiency with a load which provides a power factor equal to the manufacturer's specified minimum level (or 0,25, whichever is greater) and at power levels of 25 %, 50 % and 100 % of rated VA.		N/A
	Repeat for power factors of 0,5 and 0,75 (do not go below the manufacturer's specified minimum PF) and power levels of 25 %, 50 %, and 100 % of rated VA.		N/A
4.8	Resistive plus non-linear loads		N/A
	For stand-alone inverters, measure the efficiency with a fixed non-linear load (total harmonic distortion (THD) = $(80 \pm 5) \%$) equal to $(25 \pm 5) \%$ of the inverter's rated VA plus sufficient resistive load in parallel to achieve a total load of 25 %, 50 % and 100 % of rated VA.		N/A
	Repeat the measurements with a fixed non-linear load equivalent to $(50 \pm 5) \%$ of the inverter's rated VA plus sufficient resistive load in parallel to achieve a total load of 50% and 100% of rated VA.		N/A
	The type of non-linear load must be clearly stated in all documentation.		N/A
4.9	Complex loads		N/A
	When a non-linear plus a sufficient reactive load condition is specified for stand-alone inverters, measure the efficiency with a fixed non-linear load (THD = $(80 \pm 5) \%$) equal to $(50 \pm 5) \%$ of the inverter's rated VA plus a sufficient reactive load (PF = 0,5) in parallel to achieve a total load of 50 % and 100 % of rated VA.		N/A
	The type of complex load is clearly stated in all documentation.		N/A
5	Efficiency calculations		P
5.1	Rated output efficiency		P
	Rated output efficiency shall be calculated from measured data as follows: $\eta_R = (P_o / P_i) \times 100$	Refer to Table.	P
5.2	Partial output efficiency		P

IEC 61683			
Clause	Requirement + Test	Result - Remark	Verdict
	Partial output efficiency shall be calculated from measured data as follows: $\eta_{par} = (P_{op} / P_{ip}) \times 100$	Refer to Table.	P
5.3	Energy efficiency		P
	Energy efficiency shall be calculated from measured data as follows: $\eta_E = (W_o / W_i) \times 100$	Refer to Table.	P
5.4	Efficiency tolerances		N/A
	When an efficiency value has been guaranteed, the tolerance of this value shall be within the value at rated conditions indicated in the table 2.		N/A

6	Conditions of loading for output ports		P
6.1	Test circuit		P
	Figure 1 shows recommended test circuits for power conditioners which have a single-phase a.c. output or d.c. output. It can as well as be regarded as a single-phase representation of a test set-up for multiphase power conditioners.		P
	Figure 1a is applied to standard-alone power and utility- interactive power conditioners respectively.		P
	The proposed test circuits in figure 1 are not mandatory, but together with the test descriptions, are intended to establish a base for mutual agreement between user and manufacturer.		P
	The type of power source shall be indicated on all tests and shall adhere to the requirements of 4.1		P
6.2	Measurement procedure		P
	a) Efficiency is calculated with equation (1) or (2) using measured P_i , P_o or P_{ip} , P_{op} . dc input power P_i , P_{ip} can be measured by wattmeter W1, or determined by multiplying the d.c. voltmeter V1 and d.c. ammeter A1 readings. Output power P_o , P_{op} is measured with wattmeter W2.		P
	b) dc input voltage, which is measured by d.c. voltmeter V1, shall be varied in the defined range where the output current, which is measured with a.c. ammeter A2, is varied from low output to the rated output.		P
	c) An average indicating instrument shall be used for the d.c. voltmeter and d.c. ammeter. A true r.m.s. type of indicating instrument shall be used for the a.c. voltmeter and a.c. ammeter. The d.c. wattmeter W1 shall be a d.c. measuring type. The wattmeter W2 shall be an a.c. or d.c. measuring type according to the output.		P

IEC 61683			
Clause	Requirement + Test	Result - Remark	Verdict
	d) Power factor (PF in per cent) can be measured by a power factor meter PF, or calculated from the readings of V2, A2, W2 and as follows: $PF = (W2 / (V2 \times A2)) \times 100$		P
	e) Each meter may be an analogue type or a digital type. The measurement accuracy shall be better than 5 % of the full-scale value for each power measured. Digital power instruments for W1 and W2 are also recommended.		P
	f) An MPPT dynamically adjusts the input voltage so as to maximize the output power. In principle, the monitoring equipment shall sample all of the electrical parameters, such as input voltage and current, output power and current, within the update period of the MPPT. If the MPPT and input source (PV array or PV array simulator) interact in such a way that the input voltage varies by less than 5 %, then averaging of readings is acceptable. The averaging period shall be 30 s or longer.		P

7	Loss measurement		P
7.1	No-load loss		P
	No-load loss shall be measured as follows.		P
	If the power conditioner is a stand-alone type, the reading of d.c. input voltage, output voltage and frequency is given with meters V1, V2 and F respectively in figure 1a, and shall be adjusted to the rated values.		P
	The no-load loss is thus the indicated value of d.c. input wattmeter, W1, when the load is disconnected from the power conditioner.	Refer to Table.	P
	If the power conditioner is a utility-interactive type, the reading of d.c. input voltmeter V1, a.c. output voltmeter V2 and frequency meter F in figure 1b shall be adjusted to meet the specified voltages and frequency.		N/A
	No-load loss is thus the indicated value of d.c. input wattmeter, W1, when a.c. wattmeter, W2, indicates a zero value. For the measurement, allow the power conditioner time to transfer to its no-load operating state, if applicable.		N/A
7.2	Standby loss		P
	Standby loss shall be measured as follows.		P
	If the power conditioner is a utility-interactive type, standby loss is defined as the consumption of utility power when the power conditioner is not operating but is under standby condition. Standby loss is indicated with a.c. wattmeter, W2 in figure 1b at the rated a.c. output voltage.		P

IEC 61683			
Clause	Requirement + Test	Result - Remark	Verdict
	If the power conditioner is a stand-alone type, standby loss is defined as the consumption from the d.c. source when the power conditioner is not operating but is under standby condition. Standby loss is indicated with d.c. wattmeter, W1 in figure 1a (without a.c. or d.c. output voltage).	Refer to Table.	P

IEC 61683			
Clause	Requirement + Test	Result - Remark	Verdict

Annex A	Power conditioner description		P
	A power conditioner is defined in IEC 61277.		P
	Some types of photovoltaic system configurations relate to their purpose and size. Figure A.1 shows the generic system configuration proposed in IEC 61277. In figure A.1, the power conditioner (PC) is inside the dotted line. The power conditioner may consist of one or more of the following: d.c. conditioner, d.c./d.c. interface, inverter, a. c./a.c. interface, a.c. utility interface, and a part of master control and monitoring (MCM) subsystem. The power flows are indicated by the arrows. When a PV system has a d.c. storage subsystem, it is assumed that the storage is connected to the input of the power conditioner in parallel with the array (see figures A.2 and A.3).	This is a multi-function inverter/charger, combining functions of inverter, solar charger and battery charger to offer uninterruptible power support with portable size. The comprehensive LCD display of the product offers user-configurable settings and easy-accessible button operation such as battery charging current, AC/solar charger priority, and acceptable input voltage based on different applications.	P
	Under normal conditions, the power conditioner a.c. output voltage and frequency are constant value when the system is connected to the utility grid (in a utility-interactive type) or to the a.c. loads (in a stand-alone type). However, when a.c. loads consist of pumps or blowers with variable speed induction motors, the a.c. voltage and frequency may be variable.	The a.c. output voltage and frequency are constant value.	P
	In this standard, systems with a constant a.c. output voltage and frequency as well as systems with a d.c. output are discussed. Figures A.2 and A.3 show the configuration of the PV system and the power conditioner described in this standard.	With a constant a.c. output voltage and frequency	P

Annex B	Power efficiency and conversion factor		P
	There are two types of efficiencies shown in IEC 60146- 2; one is a power efficiency, the other is a conversion factor. Power efficiency is defined as the ratio of active output power and active input power. Conversion factor is the ratio between output and input fundamental power levels. The formulae for these two parameters: $f_{IP} = (P_{aAC}/P_{aDC}) \times 100 \quad (\%)$ $\eta_C = (P_{fAC} / P_{fDC}) \times 100 \quad (\%)$		P
	Active power P_a is calculated as $P_a = \frac{1}{T} \int_0^T v(t)i(t)dt \quad \text{or} \quad = \frac{1}{T} \int_0^T p(t)dt$		P

IEC 61683			
Clause	Requirement + Test	Result - Remark	Verdict
	The difference between the above two efficiencies is due to the evaluation of the harmonic components. IEC 60146 unifies them into power efficiency. Their differences depend on their voltage and current waveforms as shown in table B.1 and are only meaningful in case 5. Considering the purpose of IEC standards and the illustration in table B.1, the power efficiency is used as the efficiency of power conditioners.		P
	As shown in table B.1, case 1 or case 4, the difference between C and P is only 0.1% when the d.c. voltage and current ripple are 10 %pp, or when a.c. 5th r.m.s. voltage content is 2 % and the 5th current content is 5 %. This means that the conversion factor is practically the same as the power efficiency. It shall, however, be noted that in the case of a square wave, as in case 5, the power efficiency shall be used because the difference is large, i. e., $\eta_C/\eta_P = 0,81$.		P
	The integration time (duration of one cycle) T shall be 30 s or more and the resultant mean power efficiency value shall be used as the efficiency of the power conditioner.		P

Annex C	Weighted-average energy efficiency		N/A
	The energy of a power conditioner depends on both the irradiance profile and the load profile. The energy efficiency of a power conditioner shall be calculated by the ratio of the output to the input energy actually measured over a certain period (such as a month or a year).		N/A
	For reference, a method of estimating the energy efficiency using a weighted-average energy efficiency is described.		N/A
	The weighted-average energy efficiency, η_{WT} , is calculated as the sum of the products of each power level efficiency and related weighting coefficient.		N/A
	When the system is a utility-interactive type without a storage subsystem, the weighting coefficients depend on a regional irradiance duration curve.		N/A
	When the system is a stand-alone type with a storage subsystem, the weighting coefficients depend on the load duration curve.		N/A
	Clauses C.1 and C.2 show the calculation procedures for η_{WT} for utility-interactive systems and stand-alone systems.		N/A
C.1	η_{WT} of power conditioner for utility-interactive PV systems		N/A
	Utility-interactive PV systems, which have no storage and for which reverse-power flow is		N/A

IEC 61683			
Clause	Requirement + Test	Result - Remark	Verdict
	accepted, are described. In this case, d.c. power generated by the PV array is supplied direct into the power conditioner (PC). Almost all of the input power to the PC is converted to a.c. power. A part of it is dissipated as the PC loss.		
	<p>The weighted-average energy efficiency, WT, is an index to evaluate annual energy efficiency in which a weighting coefficient, Ki, is used for each input power level. Here, the irradiance is divided into several discrete levels. By using a duration time Ti, d.c. input power level, Pli, output power level, POi, and PC efficiency, i, for each level i, WT is defined as follows:</p> $f_{iWT} = \frac{\sum P_{O_i} \cdot T_i}{\sum P_{I_i} \cdot T_i} = \frac{P_{I_1} \cdot f_{I_1} \cdot T_1 + \dots + P_{I_n} \cdot f_{I_n} \cdot T_n}{P_{I_1} \cdot T_1 + \dots + P_{I_n} \cdot T_n}$ $= K_1 \cdot f_{I_1} + K_2 \cdot f_{I_2} + \dots + K_n \cdot f_{I_n}$		N/A
	<p>If the irradiance duration curve is given as shown in figure C.1, equation (C.1) can be rewritten as follows:</p> $\eta_{WT} = \frac{1T_1}{T_{WT}} \eta_{1/4} + \frac{2T_2}{T_{WT}} \eta_{2/4} + \frac{3T_3}{T_{WT}} \eta_{3/4} + \frac{4T_4}{T_{WT}} \eta_{4/4} \geq \eta_{ER}$ $T_{WT} = 1T_1 + 2T_2 + 3T_3 + 4T_4$		N/A
C.2	η_{WT} of power conditioner for stand-alone PV systems		N/A
	In stand-alone PV systems with a storage subsystem, power generated from the PV array is stored and stabilized by the batteries. dc power is converted into regulated d.c. power or constant-voltage and constant-frequency a.c. power by a power conditioner (PC) and supplied to the load. In this case, some fraction of the generated power is dissipated as a loss in the batteries and power conditioner.		N/A
	The calculation of the weighted-average energy efficiency, WT, for stand-alone PV systems requires weighting coefficients for respective load levels.		N/A
	<p>By using a load duration time Ti, d.c. input power Pli, a.c. output power POi and PC efficiency for respective load level i, WT is defined as follows:</p> $\eta_{WT} = \frac{\sum P_{O_i} \cdot T_i}{\sum P_{I_i} \cdot T_i} = \frac{\sum P_{O_1} \cdot T_1 + \dots + P_{O_n} \cdot T_n}{P_{I_0} \cdot T_0 + P_{O_1} \cdot T_1 / f_{I_1} + P_{O_n} \cdot T_n / f_{I_n}}$ $= \frac{1}{K_0 + K_1 / f_{I_1} + \dots + K_n / f_{I_n}}$		N/A
Annex D	Derivation of efficiency tolerance in table 2		N/A

TABLE 1		Efficiency recording and efficient calculation sheet								P
power conditioner type	Grid-connected									
Model:	XZ-11.2kW-18000pV									
Parameters of power conditioner	Minimum rated input voltage: 120Vdc Nominal voltage or the average of its rated input range: 360Vdc Maximum input voltage: 500Vdc (90% of Maximum input voltage: 450Vdc) Rated output voltage: 230Vac Rated output frequency: 50/60Hz Rated output power: 11200W									
PV input voltage	a) the inverter's minimum voltage									
Temperature (°C)	25°C±5°C									
Operating period for energy measurement (min)	5.0									
Resistive load										
Percentage of rated output VA	--	10%	25%	50%	75%	100%	120%*	/	/	
Pac/Pac,r [%]	--	10.04%	25.09%	49.97%	--	--	--	/	/	
Output voltage (V)	--	229.38	229.98	229.38	--	--	--	/	/	
Output current (A)	--	4.91	12.22	24.41	--	--	--	/	/	
Output power (Po) (W)	--	1125	2810	5597	--	--	--	/	/	
PF	--	0.9999	0.9999	0.9999	--	--	--	/	/	
Input voltage (V)	--	120.71	120.56	120.20	--	--	--	/	/	
Input current (A)	--	10.52	25.44	50.14	--	--	--	/	/	
Input power (Pi) (W)	--	1269	3066	6026	--	--	--	/	/	
Output efficiency [%]	--	88.65%	91.65%	92.88%	--	--	--	/	/	
Uthd [%]	--	2.27%	2.21%	2.30%	--	--	--	/	/	
Ithd [%]	--	29.00%	14.57%	9.40%	--	--	--	/	/	
Output energy (Wo) (Wh) (5min)	--	93.82	234.63	466.67	--	--	--	/	/	
Input energy (Wi) (Wh) (5min)	--	104.87	254.98	502.17	--	--	--	/	/	
Energy efficiency	--	89.46%	92.01%	92.93%	--	--	--	/	/	
Remark: *If limited by design, inverter is not capable to operate with the 120% of rated output load, test under this condition is waived; The inverter can not load to 75%, At This voltage.										

TABLE 2		Efficiency recording and efficient calculation sheet								P
power conditioner type	Grid-connected									
Model:	XZ-11.2kW-18000pV									

Parameters of power conditioner	Minimum rated input voltage: 120Vdc Nominal voltage or the average of its rated input range: 360Vdc Maximum input voltage: 500Vdc (90% of Maximum input voltage: 450Vdc) Rated output voltage: 230Vac Rated output frequency: 50/60Hz Rated output power: 11200W								
PV input voltage	b) the inverter's nominal voltage or the average of its rated input range								
Temperature (°C)	25°C±5°C								
Operating period for energy measurement (min)	5.0								
Resistive load									
Percentage of rated output VA	--	10%	25%	50%	75%	100%	120%*	/	/
Pac/Pac,r [%]	--	10.00%	25.02%	50.01%	74.98%	100.02%	--	/	/
Output voltage (V)	--	229.75	229.77	229.62	229.37	229.34	--	/	/
Output current (A)	--	4.95	12.21	24.40	36.66	48.92	--	/	/
Output power (Po) (W)	--	1120	2802	5601	8398	11202	--	/	/
PF	--	0.9863	0.9994	0.9997	0.9988	0.9985	--	/	/
Input voltage (V)	--	360.89	360.79	360.55	360.31	360.17	--	/	/
Input current (A)	--	3.38	8.22	16.27	24.44	32.58	--	/	/
Input power (Pi) (W)	--	1218	2963	5864	8803	11731	--	/	/
Output efficiency [%]	--	91.95%	94.56%	95.51%	95.39%	95.49%	--	/	/
Uthd [%]	--	2.27%	2.30%	2.21%	2.22%	2.16%	--	/	/
lthd [%]	--	29.33%	15.16%	9.18%	6.59%	5.26%	--	/	/
Output energy (Wo) (Wh) (5min)	--	93.29	233.45	467.97	699.50	919.18	--	/	/
Input energy (Wi) (Wh) (5min)	--	101.54	246.48	490.28	734.01	966.08	--	/	/
Energy efficiency	--	91.87%	94.71%	95.44%	95.29%	95.14%	--	/	/
Remark: *If limited by design, inverter is not capable to operate with the 120% of rated output load, test under this condition is waived;									

TABLE 3	Efficiency recording and efficient calculation sheet	P
power conditioner type	Grid-connected	
Model:	XZ-11.2kW-18000pV	
Parameters of power conditioner	Minimum rated input voltage: 120Vdc Nominal voltage or the average of its rated input range: 360Vdc Maximum input voltage: 500Vdc (90% of Maximum input voltage: 450Vdc) Rated output voltage: 230Vac Rated output frequency: 50/60Hz Rated output power: 11200W	

PV input voltage	c) 90 % of the inverter's maximum input voltage								
Temperature (°C)	25°C±5°C								
Operating period for energy measurement (min)	5.0								
Resistive load									
Percentage of rated output VA	--	10%	25%	50%	75%	100%	120%*	/	/
Pac/Pac,r [%]	--	10.00%	25.01%	50.00%	75.02%	100.01%	--	/	/
Output voltage (V)	--	229.80	229.85	229.57	229.37	229.22	--	/	/
Output current (A)	--	4.92	12.20	24.40	36.65	48.91	--	/	/
Output power (Po) (W)	--	1120	2801	5600	8402	11201	--	/	/
PF	--	0.9907	0.9992	0.9998	0.9997	0.9992	--	/	/
Input voltage (V)	--	450.96	450.81	450.71	450.55	450.33	--	/	/
Input current (A)	--	2.72	6.55	12.97	19.51	25.86	--	/	/
Input power (Pi) (W)	--	1224	2951	5845	8788	11642	--	/	/
Output efficiency [%]	--	91.50%	94.91%	95.80%	95.60%	96.21%	--	/	/
Uthd [%]	--	2.30%	2.25%	2.14%	2.20%	2.19%	--	/	/
lthd [%]	--	28.95%	13.96%	8.00%	5.83%	4.72%	--	/	/
Output energy (Wo) (Wh) (5min)	--	94.22	234.08	467.29	702.76	924.66	--	/	/
Input energy (Wi) (Wh) (5min)	--	103.54	247.11	488.57	740.83	968.01	--	/	/
Energy efficiency	--	90.99%	94.72%	95.64%	94.86%	95.52%	--	/	/
Remark: *If limited by design, inverter is not capable to operate with the 120% of rated output load, test under this condition is waived;									

TABLE 4	Efficiency recording and efficient calculation sheet	P
power conditioner type	Stand-alone(BAT to load)	
Model:	XZ-11.2kW-18000pV	
Parameters of power conditioner	Minimum rated input voltage: --Vdc Nominal voltage or the average of its rated input range: 48Vdc Maximum input voltage: --Vdc Rated output voltage: 230Vac Rated output frequency: 50/60Hz Rated output power: 11200W	
PV input voltage	b) the inverter's nominal voltage or the average of its rated input range	
Temperature (°C)	25°C±5°C	
Operating period for energy measurement (min)	5.0	
Resistive load		

Percentage of rated output VA	5%	10%	25%	50%	75%	100%	120%*	/	/
Pac/Pac,r [%]	5.00%	9.97%	25.00%	49.98%	75.01%	90.38%	--	/	/
Output voltage (V)	231.60	231.69	231.47	231.40	231.03	230.96	--	/	/
Output current (A)	2.42	4.83	12.10	24.20	36.37	43.84	--	/	/
Output power (Po) (W)	560	1117	2800	5598	8401	10123	--	/	/
PF	0.9997	0.9999	1.0000	1.0000	1.0000	1.0000	--	/	/
Input voltage (V)	48.91	48.83	48.74	48.62	48.44	54.07	--	/	/
Input current (A)	13.87	25.69	62.40	125.57	192.84	207.18	--	/	/
Input power (Pi) (W)	678	1254	3041	6105	9341	11202	--	/	/
Output efficiency [%]	82.59%	89.07%	92.07%	91.69%	89.93%	90.36%	--	/	/
Uthd [%]	3.34%	3.35%	3.19%	3.50%	3.75%	3.78%	--	/	/
lthd [%]	3.38%	3.29%	3.10%	3.40%	3.72%	3.74%	--	/	/
Output energy (Wo) (Wh) (5min)	46.70	92.97	233.34	466.44	700.04	842.35	--	/	/
Input energy (Wi) (Wh) (5min)	56.75	104.79	253.08	508.56	778.45	933.20	--	/	/
Energy efficiency	82.29%	88.72%	92.20%	91.71%	89.92%	90.26%	--	/	/

Remark:

*If limited by design, inverter is not capable to operate with the 120% of rated output load, test under this condition is waived;

TABLE 5	Efficiency recording and efficient calculation sheet								P	
power conditioner type	Stand-alone(PV to load)									
Model:	XZ-11.2kW-18000pV									
Parameters of power conditioner	Minimum rated input voltage: 120Vdc Nominal voltage or the average of its rated input range: 360Vdc Maximum input voltage: 500Vdc (90% of Maximum input voltage: 450Vdc) Rated output voltage: 230Vac Rated output frequency: 50/60Hz Rated output power: 11200W									
PV input voltage	a) the inverter's minimum voltage									
Temperature (°C)	25°C±5°C									
Operating period for energy measurement (min)	5.0									
Resistive load										
Percentage of rated output VA	5%	10%	25%	50%	75%	100%	120%*	/	/	
Pac/Pac,r [%]	5.00%	9.96%	25.00%	49.98%	--	--	--	/	/	
Output voltage (V)	231.52	231.61	231.44	231.39	--	--	--	/	/	
Output current (A)	2.42	4.82	12.10	24.20	--	--	--	/	/	
Output power (Po) (W)	560	1116	2800	5598	--	--	--	/	/	

PF	0.9999	1.0000	1.0000	1.0000	--	--	--	/	/
Input voltage (V)	120.91	120.88	120.68	120.23	--	--	--	/	/
Input current (A)	5.46	10.25	25.05	50.12	--	--	--	/	/
Input power (Pi) (W)	660	1238	3022	6025	--	--	--	/	/
Output efficiency [%]	84.84%	90.14%	92.65%	92.91%	--	--	--	/	/
Uthd [%]	1.92%	3.51%	3.11%	3.40%	--	--	--	/	/
lthd [%]	1.99%	3.45%	3.02%	3.31%	--	--	--	/	/
Output energy (Wo) (Wh) (5min)	46.73	92.96	233.25	465.89	--	--	--	/	/
Input energy (Wi) (Wh) (5min)	54.93	103.13	251.77	501.69	--	--	--	/	/
Energy efficiency	85.07%	90.13%	92.64%	92.86%	--	--	--	/	/
<p>Remark:</p> <p>*If limited by design, inverter is not capable to operate with the 120% of rated output load, test under this condition is waived;</p> <p>The inverter can not load to 75%, At This voltage.</p>									

TABLE 6	Efficiency recording and efficient calculation sheet							P	
power conditioner type	Stand-alone(PV to load)								
Model:	XZ-11.2kW-18000pV								
Parameters of power conditioner	Minimum rated input voltage: 120Vdc Nominal voltage or the average of its rated input range: 360Vdc Maximum input voltage: 500Vdc (90% of Maximum input voltage: 450Vdc) Rated output voltage: 230Vac Rated output frequency: 50/60Hz Rated output power: 11200W								
PV input voltage	b) the inverter's nominal voltage or the average of its rated input range								
Temperature (°C)	25°C±5°C								
Operating period for energy measurement (min)	5.0								
Resistive load									
Percentage of rated output VA	5%	10%	25%	50%	75%	100%	120%*	/	/
Pac/Pac,r [%]	5.00%	9.96%	25.00%	49.97%	75.00%	99.99%	--	/	/
Output voltage (V)	231.57	231.62	231.49	231.36	230.97	230.67	--	/	/
Output current (A)	2.42	4.82	12.10	24.20	36.37	48.55	--	/	/
Output power (Po) (W)	560	1116	2800	5597	8400	11199	--	/	/
PF	0.9999	1.0000	1.0000	1.0000	1.0000	1.0000	--	/	/
Input voltage (V)	360.88	360.73	360.65	360.47	360.29	360.15	--	/	/
Input current (A)	1.78	3.35	8.14	16.20	24.40	32.60	--	/	/
Input power (Pi) (W)	640	1205	2934	5839	8788	11740	--	/	/
Output efficiency [%]	87.50%	92.61%	95.43%	95.85%	95.58%	95.39%	--	/	/

Uthd [%]	1.56%	3.69%	3.21%	3.42%	3.66%	3.79%	--	/	/
lthd [%]	1.65%	3.63%	3.12%	3.33%	3.62%	3.73%	--	/	/
Output energy (Wo) (Wh) (5min)	46.75	92.96	233.26	465.93	699.90	933.32	--	/	/
Input energy (Wi) (Wh) (5min)	53.25	100.37	244.48	486.03	732.29	978.11	--	/	/
Energy efficiency	87.79%	92.61%	95.41%	95.86%	95.57%	95.42%	--	/	/

Remark:

*If limited by design, inverter is not capable to operate with the 120% of rated output load, test under this condition is waived;

TABLE 7	Efficiency recording and efficient calculation sheet							P	
power conditioner type	Stand-alone(PV to load)								
Model:	XZ-11.2kW-18000pV								
Parameters of power conditioner	Minimum rated input voltage: 120Vdc Nominal voltage or the average of its rated input range: 360Vdc Maximum input voltage: 500Vdc (90% of Maximum input voltage: 450Vdc) Rated output voltage: 230Vac Rated output frequency: 50/60Hz Rated output power: 11200W								
PV input voltage	c) 90 % of the inverter's maximum input voltage								
Temperature (°C)	25°C±5°C								
Operating period for energy measurement (min)	5.0								
Resistive load									
Percentage of rated output VA	5%	10%	25%	50%	75%	100%	120%*	/	/
Pac/Pac,r [%]	5.00%	9.96%	25.01%	49.98%	75.01%	100.00%	--	/	/
Output voltage (V)	231.54	231.56	231.39	231.36	231.00	230.68	--	/	/
Output current (A)	2.42	4.82	12.11	24.20	36.37	48.56	--	/	/
Output power (Po) (W)	560	1115	2801	5598	8401	11200	--	/	/
PF	0.9999	1.0000	1.0000	1.0000	1.0000	1.0000	--	/	/
Input voltage (V)	450.83	450.79	450.65	450.42	450.23	450.17	--	/	/
Input current (A)	1.46	2.70	6.53	12.96	19.48	26.04	--	/	/
Input power (Pi) (W)	657	1215	2941	5836	8769	11718	--	/	/
Output efficiency [%]	85.23%	91.76%	95.23%	95.92%	95.80%	95.57%	--	/	/
Uthd [%]	0.67%	1.32%	3.27%	3.31%	3.39%	3.44%	--	/	/
lthd [%]	0.84%	1.31%	3.17%	3.20%	3.34%	3.36%	--	/	/
Output energy (Wo) (Wh) (5min)	46.73	92.95	233.51	466.08	700.00	933.10	--	/	/
Input energy (Wi) (Wh) (5min)	54.82	101.25	245.20	485.82	730.52	975.87	--	/	/

Energy efficiency	85.24%	91.80%	95.23%	95.93%	95.82%	95.61%	--	/	/
Remark: *If limited by design, inverter is not capable to operate with the 120% of rated output load, test under this condition is waived;									

TABLE 8	No load loss	P
power conditioner type	(Grid mode)	
Measure input voltage (V)	120Vdc/360Vdc/450Vdc	
Measured input power(W)	58W/68W/94W	
power conditioner type	(Inverter mode)	
Measure input voltage (V)	48Vdc	
Measured input power(W)	100W	
power conditioner type	(PV mode)	
Measure input voltage (V)	120Vdc/360Vdc/450Vdc	
Measured input power(W)	58W/68W/94W	
Remark: No load loss is measured when the power conditioner works at rated input voltage and it's load is disconnected.		

TABLE 9	Standby loss	P
power conditioner type	(Grid mode)	
Measure input voltage (V)	120Vdc/360Vdc/450Vdc	
Measured input power(W)	18W/18W/20W	
power conditioner type	(Inverter mode)	
Measure input voltage (V)	48Vdc	
Measured input power(W)	29W	
power conditioner type	(PV mode)	
Measure input voltage (V)	120Vdc/360Vdc/450Vdc	
Measured input power(W)	18W/18W/20W	
Remark: Standby loss is measured when the power conditioner works at rated input voltage and in standby mode.		

TABLE 1		Efficiency recording and efficient calculation sheet								P	
power conditioner type		Grid-connected									
Model:		XZ-9.2kW-16000pV									
Parameters of power conditioner		Minimum rated input voltage: 120Vdc Nominal voltage or the average of its rated input range: 360Vdc Maximum input voltage: 500Vdc (90% of Maximum input voltage: 450Vdc) Rated output voltage: 230Vac Rated output frequency: 50/60Hz Rated output power: 9200W									
PV input voltage		a) the inverter's minimum voltage									
Temperature (°C)		25°C±5°C									
Operating period for energy measurement (min)		5.0									
Resistive load											
Percentage of rated output VA	--	10%	25%	50%	75%	100%	120%*	/	/	/	/
Pac/Pac,r [%]	--	10.01%	25.02%	50.03%	--	--	--	/	/	/	/
Output voltage (V)	--	230.55	230.42	230.36	--	--	--	/	/	/	/
Output current (A)	--	4.08	10.00	20.00	--	--	--	/	/	/	/
Output power (Po) (W)	--	921	2302	4603	--	--	--	/	/	/	/
PF	--	0.9800	0.9998	0.9994	--	--	--	/	/	/	/
Input voltage (V)	--	120.80	120.78	120.65	--	--	--	/	/	/	/
Input current (A)	--	8.58	20.66	40.92	--	--	--	/	/	/	/
Input power (Pi) (W)	--	1036	2495	4936	--	--	--	/	/	/	/
Output efficiency [%]	--	88.89%	92.26%	93.25%	--	--	--	/	/	/	/
Uthd [%]	--	3.00%	3.11%	2.91%	--	--	--	/	/	/	/
Ithd [%]	--	43.82%	22.22%	12.20%	--	--	--	/	/	/	/
Output energy (Wo) (Wh) (5min)	--	76.55	191.48	383.42	--	--	--	/	/	/	/
Input energy (Wi) (Wh) (5min)	--	85.87	206.92	410.72	--	--	--	/	/	/	/
Energy efficiency	--	89.14%	92.53%	93.35%	--	--	--	/	/	/	/
Remark: *If limited by design, inverter is not capable to operate with the 120% of rated output load, test under this condition is waived; The inverter can not load to 75%, At This voltage.											

TABLE 2		Efficiency recording and efficient calculation sheet								P	
power conditioner type		Grid-connected									
Model:		XZ-9.2kW-16000pV									

Parameters of power conditioner	Minimum rated input voltage: 120Vdc Nominal voltage or the average of its rated input range: 360Vdc Maximum input voltage: 500Vdc (90% of Maximum input voltage: 450Vdc) Rated output voltage: 230Vac Rated output frequency: 50/60Hz Rated output power: 9200W								
PV input voltage	b) the inverter's nominal voltage or the average of its rated input range								
Temperature (°C)	25°C±5°C								
Operating period for energy measurement (min)	5.0								
Resistive load									
Percentage of rated output VA	--	10%	25%	50%	75%	100%	120%*	/	/
Pac/Pac,r [%]	--	10.03%	25.17%	50.00%	74.98%	99.99%	--	/	/
Output voltage (V)	--	230.24	230.12	230.42	230.09	229.97	--	/	/
Output current (A)	--	5.02	10.07	19.97	29.99	40.01	--	/	/
Output power (Po) (W)	--	923	2316	4600	6898	9199	--	/	/
PF	--	0.9846	0.9995	0.9998	0.9999	0.9998	--	/	/
Input voltage (V)	--	360.82	360.75	360.60	360.48	360.27	--	/	/
Input current (A)	--	2.84	6.79	13.36	20.00	26.74	--	/	/
Input power (Pi) (W)	--	1024	2446	4815	7209	9633	--	/	/
Output efficiency [%]	--	90.13%	94.68%	95.53%	95.68%	95.49%	--	/	/
Uthd [%]	--	3.03%	3.58%	3.35%	3.37%	3.24%	--	/	/
lthd [%]	--	44.04%	22.45%	14.28%	10.01%	7.51%	--	/	/
Output energy (Wo) (Wh) (5min)	--	77.29	193.19	382.61	574.73	766.52	--	/	/
Input energy (Wi) (Wh) (5min)	--	84.96	203.74	399.60	600.38	801.77	--	/	/
Energy efficiency	--	90.97%	94.82%	95.74%	95.72%	95.60%	--	/	/
Remark: *If limited by design, inverter is not capable to operate with the 120% of rated output load, test under this condition is waived;									

TABLE 3	Efficiency recording and efficient calculation sheet	P
power conditioner type	Grid-connected	
Model:	XZ-9.2kW-16000pV	
Parameters of power conditioner	Minimum rated input voltage: 120Vdc Nominal voltage or the average of its rated input range: 360Vdc Maximum input voltage: 500Vdc (90% of Maximum input voltage: 450Vdc) Rated output voltage: 230Vac Rated output frequency: 50/60Hz Rated output power: 9200W	

PV input voltage	c) 90 % of the inverter's maximum input voltage								
Temperature (°C)	25°C±5°C								
Operating period for energy measurement (min)	5.0								
Resistive load									
Percentage of rated output VA	--	10%	25%	50%	75%	100%	120%*	/	/
Pac/Pac,r [%]	--	10.01%	25.00%	49.99%	75.04%	100.02%	--	/	/
Output voltage (V)	--	230.61	230.08	230.75	230.53	230.57	--	/	/
Output current (A)	--	4.03	10.01	19.94	29.96	39.94	--	/	/
Output power (Po) (W)	--	921	2300	4599	6904	9202	--	/	/
PF	--	0.9933	0.9992	0.9997	0.9998	0.9994	--	/	/
Input voltage (V)	--	450.83	450.77	450.66	450.33	450.18	--	/	/
Input current (A)	--	2.27	5.39	10.66	15.95	21.29	--	/	/
Input power (Pi) (W)	--	1022	2429	4803	7182	9582	--	/	/
Output efficiency [%]	--	90.11%	94.68%	95.75%	96.12%	96.03%	--	/	/
Uthd [%]	--	3.30%	3.07%	3.15%	3.10%	3.15%	--	/	/
lthd [%]	--	46.56%	19.62%	11.87%	8.66%	6.77%	--	/	/
Output energy (Wo) (Wh) (5min)	--	76.81	192.15	383.91	575.27	767.77	--	/	/
Input energy (Wi) (Wh) (5min)	--	85.13	202.76	400.30	597.98	798.91	--	/	/
Energy efficiency	--	90.22%	94.76%	95.90%	96.20%	96.10%	--	/	/
Remark: *If limited by design, inverter is not capable to operate with the 120% of rated output load, test under this condition is waived;									

TABLE 4	Efficiency recording and efficient calculation sheet	P
power conditioner type	Stand-alone(BAT to load)	
Model:	XZ-9.2kW-16000pV	
Parameters of power conditioner	Minimum rated input voltage: --Vdc Nominal voltage or the average of its rated input range: 48Vdc Maximum input voltage: --Vdc Rated output voltage: 230Vac Rated output frequency: 50/60Hz Rated output power: 9200W	
PV input voltage	b) the inverter's nominal voltage or the average of its rated input range	
Temperature (°C)	25°C±5°C	
Operating period for energy measurement (min)	5.0	
Resistive load		

Percentage of rated output VA	5%	10%	25%	50%	75%	100%	120%*	/	/
Pac/Pac,r [%]	4.99%	10.00%	25.03%	50.01%	75.01%	99.95%	--	/	/
Output voltage (V)	229.93	229.99	229.75	229.67	229.58	229.25	--	/	/
Output current (A)	2.0	4.01	10.03	20.04	30.06	40.11	--	/	/
Output power (Po) (W)	459	920	2303	4601	6901	9195	--	/	/
PF	0.9999	1.0000	1.0000	1.0000	1.0000	1.0000	--	/	/
Input voltage (V)	48.83	48.79	48.62	48.43	48.24	54.66	--	/	/
Input current (A)	11.58	21.32	51.32	102.40	156.24	189.95	--	/	/
Input power (Pi) (W)	565	1040	2495	4959	7537	10382	--	/	/
Output efficiency [%]	81.23%	88.46%	92.30%	92.78%	91.56%	88.56%	--	/	/
Uthd [%]	1.34%	2.83%	2.37%	2.61%	2.87%	2.97%	--	/	/
lthd [%]	7.28%	4.50%	2.93%	2.84%	2.98%	3.02%	--	/	/
Output energy (Wo) (Wh) (5min)	38.22	76.59	192.17	383.63	574.96	766.45	--	/	/
Input energy (Wi) (Wh) (5min)	47.35	86.90	208.30	413.83	627.28	864.87	--	/	/
Energy efficiency	80.71%	88.13%	92.25%	92.70%	91.65%	88.62%	--	/	/

Remark:

*If limited by design, inverter is not capable to operate with the 120% of rated output load, test under this condition is waived;

TABLE 5	Efficiency recording and efficient calculation sheet								P	
power conditioner type	Stand-alone(PV to load)									
Model:	XZ-9.2kW-16000pV									
Parameters of power conditioner	Minimum rated input voltage: 120Vdc Nominal voltage or the average of its rated input range: 360Vdc Maximum input voltage: 500Vdc (90% of Maximum input voltage: 450Vdc) Rated output voltage: 230Vac Rated output frequency: 50/60Hz Rated output power: 9200W									
PV input voltage	a) the inverter's minimum voltage									
Temperature (°C)	25°C±5°C									
Operating period for energy measurement (min)	5.0									
Resistive load										
Percentage of rated output VA	5%	10%	25%	50%	75%	100%	120%*	/	/	
Pac/Pac,r [%]	4.96%	10.07%	25.00%	50.01%	--	--	--	/	/	
Output voltage (V)	229.92	229.82	229.80	229.71	--	--	--	/	/	
Output current (A)	1.99	4.03	10.01	20.03	--	--	--	/	/	
Output power (Po) (W)	456	926	2300	4601	--	--	--	/	/	

PF	0.9998	0.9999	1.0000	1.0000	--	--	--	/	/
Input voltage (V)	120.85	120.75	120.61	120.25	--	--	--	/	/
Input current (A)	4.56	8.58	20.54	40.90	--	--	--	/	/
Input power (Pi) (W)	550	1036	2477	4918	--	--	--	/	/
Output efficiency [%]	82.90%	89.38%	92.85%	93.55%	--	--	--	/	/
Uthd [%]	0.72%	2.94%	2.35%	2.47%	--	--	--	/	/
lthd [%]	1.60%	2.97%	2.41%	2.52%	--	--	--	/	/
Output energy (Wo) (Wh) (5min)	37.99	77.19	191.57	383.29	--	--	--	/	/
Input energy (Wi) (Wh) (5min)	45.67	86.31	206.51	409.53	--	--	--	/	/
Energy efficiency	83.18%	89.43%	92.76%	93.59%	--	--	--	/	/
<p>Remark:</p> <p>*If limited by design, inverter is not capable to operate with the 120% of rated output load, test under this condition is waived;</p> <p>The inverter can not load to 75%, At This voltage.</p>									

TABLE 6	Efficiency recording and efficient calculation sheet							P	
power conditioner type	Stand-alone(PV to load)								
Model:	XZ-9.2kW-16000pV								
Parameters of power conditioner	Minimum rated input voltage: 120Vdc Nominal voltage or the average of its rated input range: 360Vdc Maximum input voltage: 500Vdc (90% of Maximum input voltage: 450Vdc) Rated output voltage: 230Vac Rated output frequency: 50/60Hz Rated output power: 9200W								
PV input voltage	b) the inverter's nominal voltage or the average of its rated input range								
Temperature (°C)	25°C±5°C								
Operating period for energy measurement (min)	5.0								
Resistive load									
Percentage of rated output VA	5%	10%	25%	50%	75%	100%	120%*	/	/
Pac/Pac,r [%]	4.95%	9.95%	25.01%	49.99%	74.99%	100.00%	--	/	/
Output voltage (V)	229.81	229.90	229.86	229.69	229.39	229.24	--	/	/
Output current (A)	1.99	3.99	10.02	20.03	30.08	40.14	--	/	/
Output power (Po) (W)	455	915	2301	4599	6899	9200	--	/	/
PF	0.9999	0.9999	1.0000	1.0000	1.0000	1.0000	--	/	/
Input voltage (V)	360.85	360.79	360.64	360.56	360.43	360.57	--	/	/
Input current (A)	1.48	2.79	6.72	13.29	19.96	26.65	--	/	/
Input power (Pi) (W)	534	1003	2421	4791	7192	9601	--	/	/
Output efficiency [%]	85.20%	91.22%	95.04%	95.99%	95.92%	95.82%	--	/	/

Uthd [%]	0.66%	2.94%	2.32%	2.51%	2.83%	3.07%	--	/	/
lthd [%]	1.20%	2.96%	2.28%	2.47%	2.80%	3.05%	--	/	/
Output energy (Wo) (Wh) (5min)	37.99	76.18	191.57	383.13	575.22	766.92	--	/	/
Input energy (Wi) (Wh) (5min)	44.56	83.47	201.67	399.13	599.59	800.36	--	/	/
Energy efficiency	85.25%	91.26%	94.99%	95.99%	95.93%	95.82%	--	/	/
Remark: *If limited by design, inverter is not capable to operate with the 120% of rated output load, test under this condition is waived;									

TABLE 7	Efficiency recording and efficient calculation sheet							P	
power conditioner type	Stand-alone(PV to load)								
Model:	XZ-9.2kW-16000pV								
Parameters of power conditioner	Minimum rated input voltage: 120Vdc Nominal voltage or the average of its rated input range: 360Vdc Maximum input voltage: 500Vdc (90% of Maximum input voltage: 450Vdc) Rated output voltage: 230Vac Rated output frequency: 50/60Hz Rated output power: 9200W								
PV input voltage	c) 90 % of the inverter's maximum input voltage								
Temperature (°C)	25°C±5°C								
Operating period for energy measurement (min)	5.0								
Resistive load									
Percentage of rated output VA	5%	10%	25%	50%	75%	100%	120%*	/	/
Pac/Pac,r [%]	4.96%	9.95%	25.00%	49.96%	75.00%	99.99%	--	/	/
Output voltage (V)	229.96	230.00	229.79	229.64	229.33	229.22	--	/	/
Output current (A)	1.99	3.98	10.01	20.02	30.09	40.14	--	/	/
Output power (Po) (W)	456	915	2300	4596	6900	9199	--	/	/
PF	0.9999	0.9999	1.0000	1.0000	1.0000	1.0000	--	/	/
Input voltage (V)	450.81	450.76	450.59	450.64	450.42	450.13	--	/	/
Input current (A)	1.22	2.25	5.38	10.61	15.93	21.24	--	/	/
Input power (Pi) (W)	548	1012	2420	4779	7174	9560	--	/	/
Output efficiency [%]	83.21%	90.41%	95.04%	96.17%	96.18%	96.22%	--	/	/
Uthd [%]	0.83%	0.77%	2.58%	2.53%	2.72%	2.83%	--	/	/
lthd [%]	1.90%	1.13%	2.55%	2.45%	2.66%	2.82%	--	/	/
Output energy (Wo) (Wh) (5min)	37.99	76.19	191.71	383.13	575.56	766.75	--	/	/
Input energy (Wi) (Wh) (5min)	45.65	84.32	201.85	398.45	598.44	797.63	--	/	/

Energy efficiency	83.22%	90.35%	94.97%	96.15%	96.17%	96.12%	--	/	/
Remark: *If limited by design, inverter is not capable to operate with the 120% of rated output load, test under this condition is waived;									

TABLE 8	No load loss	P
power conditioner type	(Grid mode)	
Measure input voltage (V)	120Vdc/360Vdc/450Vdc	
Measured input power(W)	70W/68W/91W	
power conditioner type	(Inverter mode)	
Measure input voltage (V)	48Vdc	
Measured input power(W)	97W	
power conditioner type	(Stand-alone)	
Measure input voltage (V)	120Vdc/360Vdc/450Vdc	
Measured input power(W)	70W/68W/91W	
Remark: No load loss is measured when the power conditioner works at rated input voltage and it's load is disconnected.		

TABLE 9	Standby loss	P
power conditioner type	(Grid mode)	
Measure input voltage (V)	120Vdc/360Vdc/450Vdc	
Measured input power(W)	18W/24W/27W	
power conditioner type	(Inverter mode)	
Measure input voltage (V)	48Vdc	
Measured input power(W)	32W	
power conditioner type	(Stand-alone)	
Measure input voltage (V)	120Vdc/360Vdc/450Vdc	
Measured input power(W)	18W/24W/27W	
Remark: Standby loss is measured when the power conditioner works at rated input voltage and in standby mode.		

Photo documentation
For model: XZ-11.2kW-18000pV

Over view-1



Over view-2



Over view-3

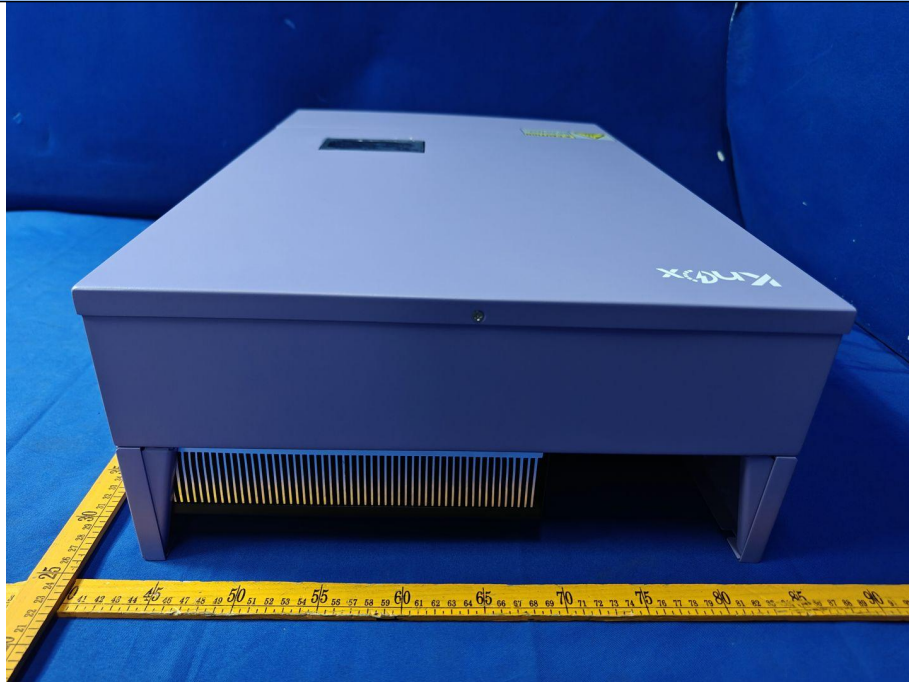

Over view-4



Over view-5

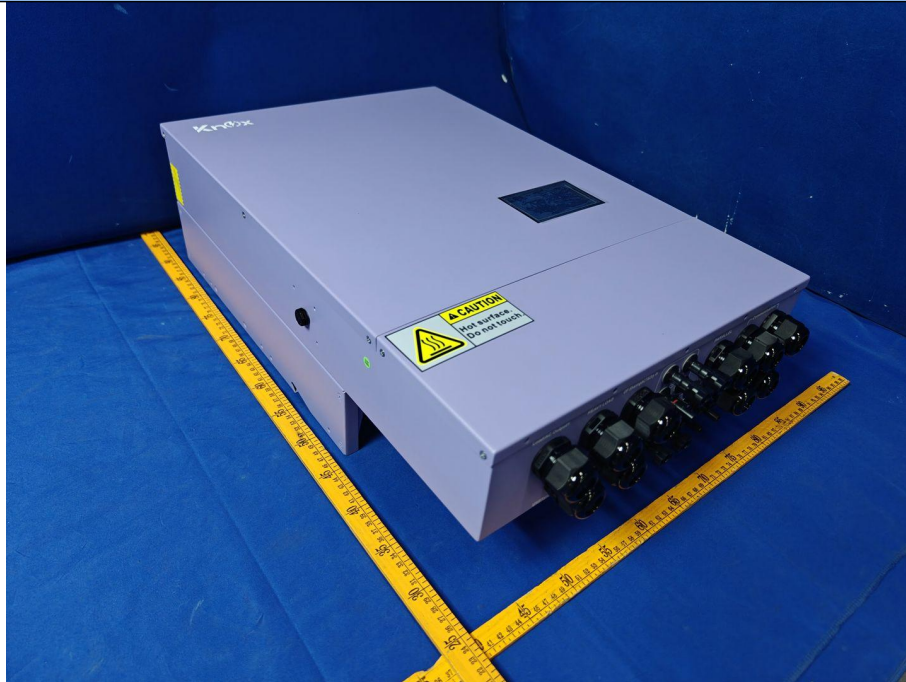

Over view-6

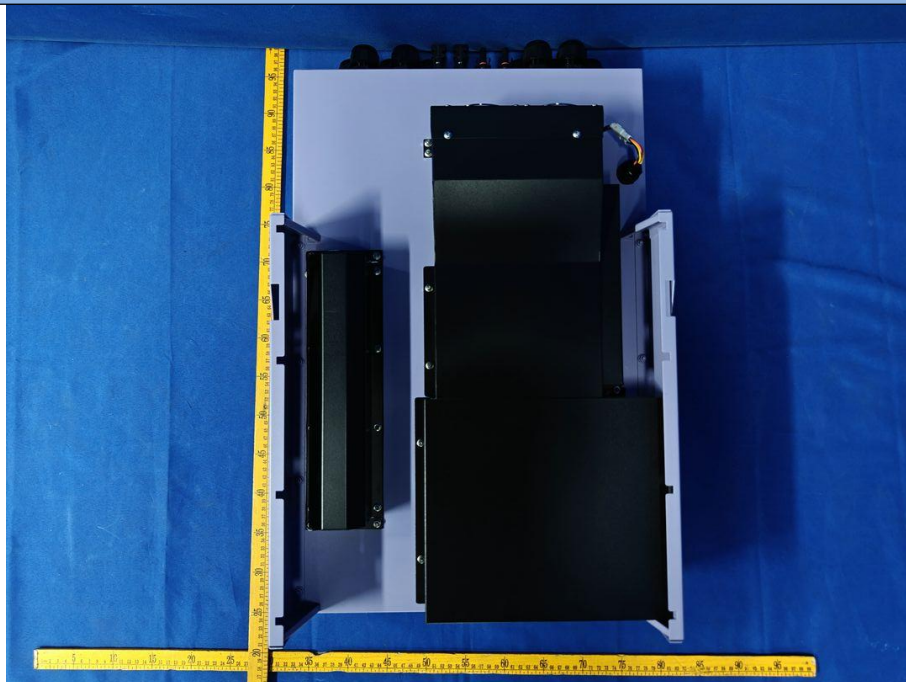

For model: XZ-9.2kW-16000pV

Over view-1



Over view-2

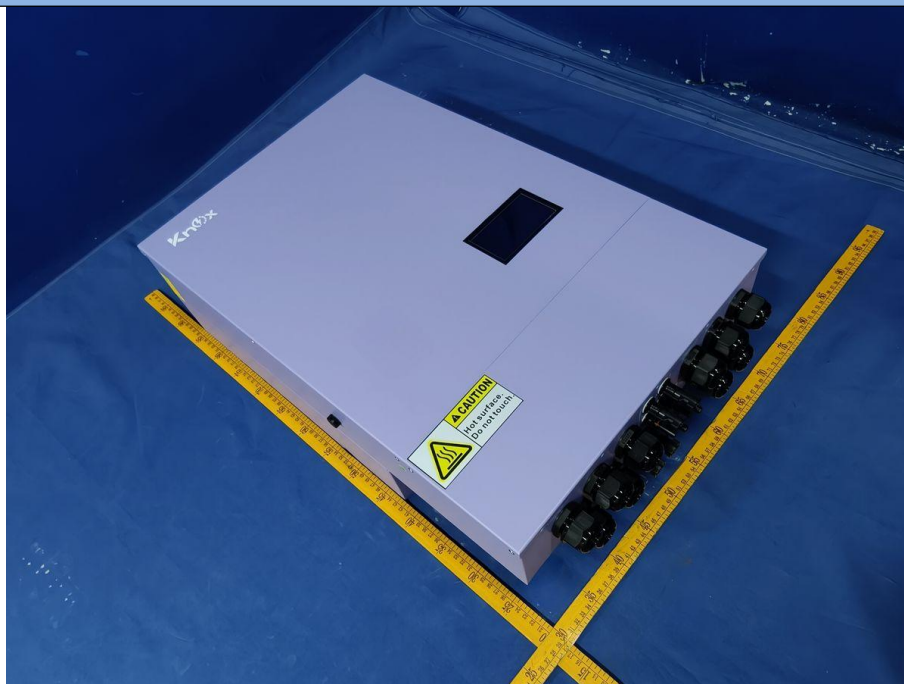

Over view-3

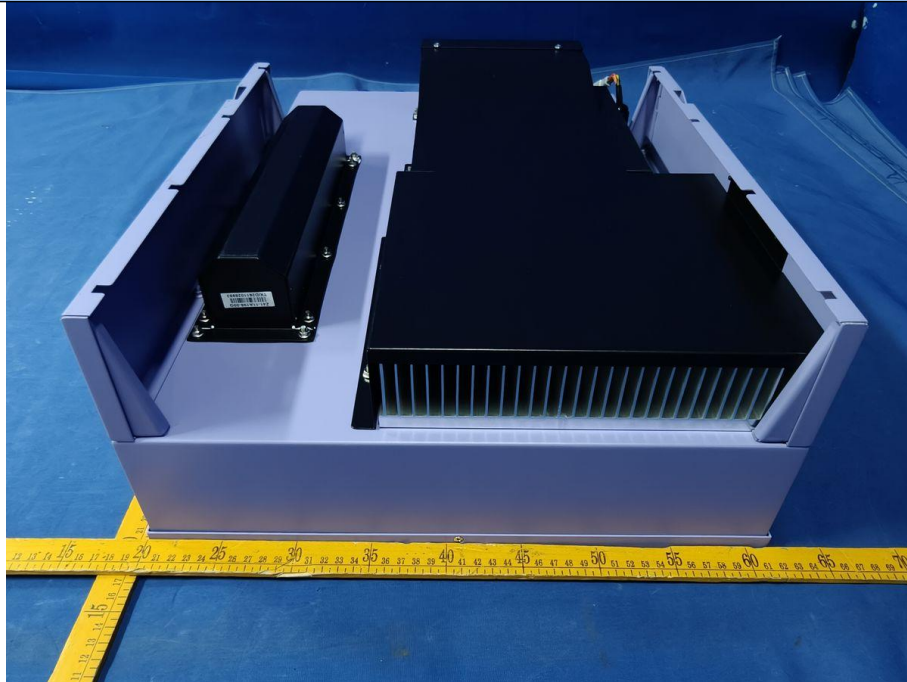

Over view-4

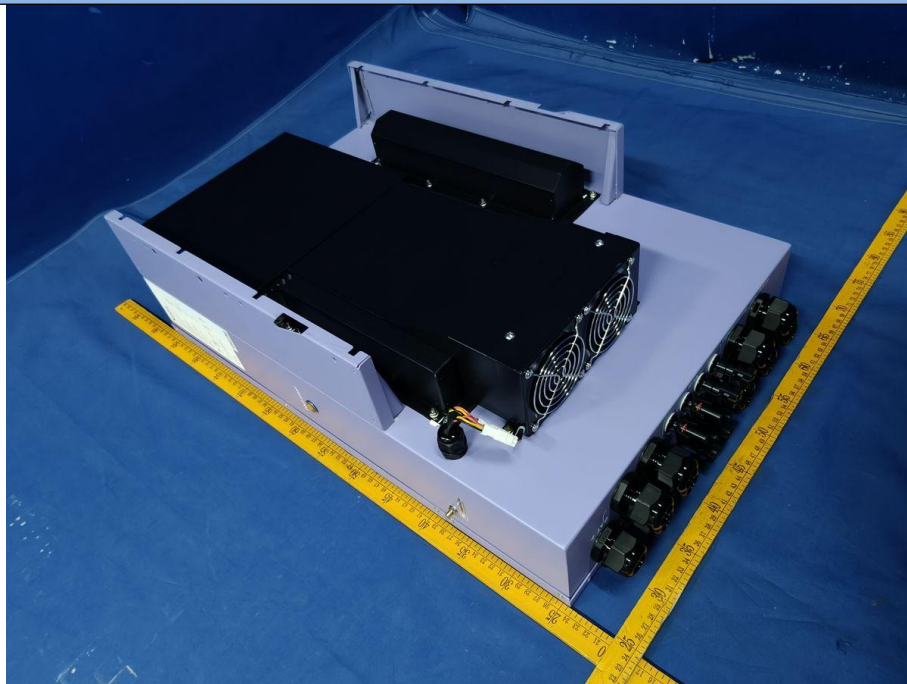

-----END OF THIS TEST REPORT-----